

SONO-VIEW

More Information:

www.imko.de



Thank you for purchasing this IMKO product

This manual is an original operating manual of the manufacturer.

The described instructions for use and commissioning are part of the products described and must be kept for future installation or use.

Important!

Please read these instructions carefully to accomplish optimum results with your moisture probe. Please contact your authorized dealer, distributor or service center for troubleshooting, questions or suggestions on your new moisture probe. You may contact IMKO directly, too after exploring your local contact.

We look forward to helping you!

For warranty claims, please contact your local dealer, distributor or service center. The warranty does not include any kind of willful damage to the device or its accessories or an operation outside of the product specification. Please refer to the information in this manual. If you have any questions, please contact IMKO service. Don't open the device and please do not try to repair the device yourself- the guarantee expires when the device is opened or modified.

In the course of product improvements, we reserve the right to make technical and visual changes to the device.

Content

1	General Notices	4
1.1	Intended Use.....	4
1.2	Temperatures and environmental conditions	4
2	Control Elements / Connections	5
2.1	Control Elements.....	5
2.2	Connections	5
3	Initial Commissioning	6
3.1	Safety Instructions	6
3.2	Checking the Package Content for Completeness	6
3.3	Connection	6
4	Operation	8
4.1	Initial and New Installation	8
4.2	Measurement Value Display	9
4.3	Settings.....	10
4.3.1	New Installation.....	10
4.3.2	Language	10
4.3.3	Unit (Temp.).....	10
4.3.4	LCD Contrast.....	11
4.3.5	Info.....	11
4.3.6	USB/IMP-Bridge.....	11
4.4	Probe Settings	12
4.4.1	Sensor Info.....	13
4.4.2	Material Calibration.....	13
4.4.2.1	Choose	13
4.4.2.2	Change	14
4.4.2.2.1	1-Point	14
4.4.2.2.2	-2-Point	16
4.4.3	Offset Balancing	19
4.4.4	Averaging Mode	19
4.4.5	Averaging Parameters	20
4.4.6	Basis Balancing	22
4.4.7	Analog Parameter.....	23
4.4.8	Analog Simulation	23
5	Technical Data.....	24
6	Safety Notes	25
7	Notes.....	27

1 General Notices

1.1 Intended Use

This device was developed as a readout device for various IMKO probes. Only dedicated probes may be connected to this device. The connection of a probe not intended for this purpose can lead to the destruction of this device and / or the connected probe.

1.2 Temperatures and environmental conditions

The SONO-VIEW has been developed for operation in harsh environments. Operation outside of the conditions specified below can damage the device.

2 Control Elements / Connections

2.1 Control Elements



2.2 Connections

- USB (Type-Mini B)
- USB-IMP-Bridge
- Supply Voltage
- Bus-Interface



3 Initial Commissioning

3.1 Safety Instructions

Attention:

It is strictly necessary to read the General Notices contained under Item 1 at the beginning of the operating instructions. Any not intended use of the device can lead to damage to this device.

3.2 Checking the Package Content for Completeness

- SONO-VIEW
- Terminal Block
- USB Cable (Type A → Mini B)
- DIN rail
- DIN rail holder
- Manual

3.3 Connection

For operation, the SONO-VIEW requires a supply voltage of 12...24V (approx. 50..30mA). A joint ground wire together with the probes is required.



NOTE:

The SONO-VIEW is suited for the display and configuration of up to eight probes. Should more than eight probes be connected, an error message will be generated, and the device cannot operate correctly.

Connection example:

Connection of the SONO-VIEW with two SONO probes and one joint voltage supply source.

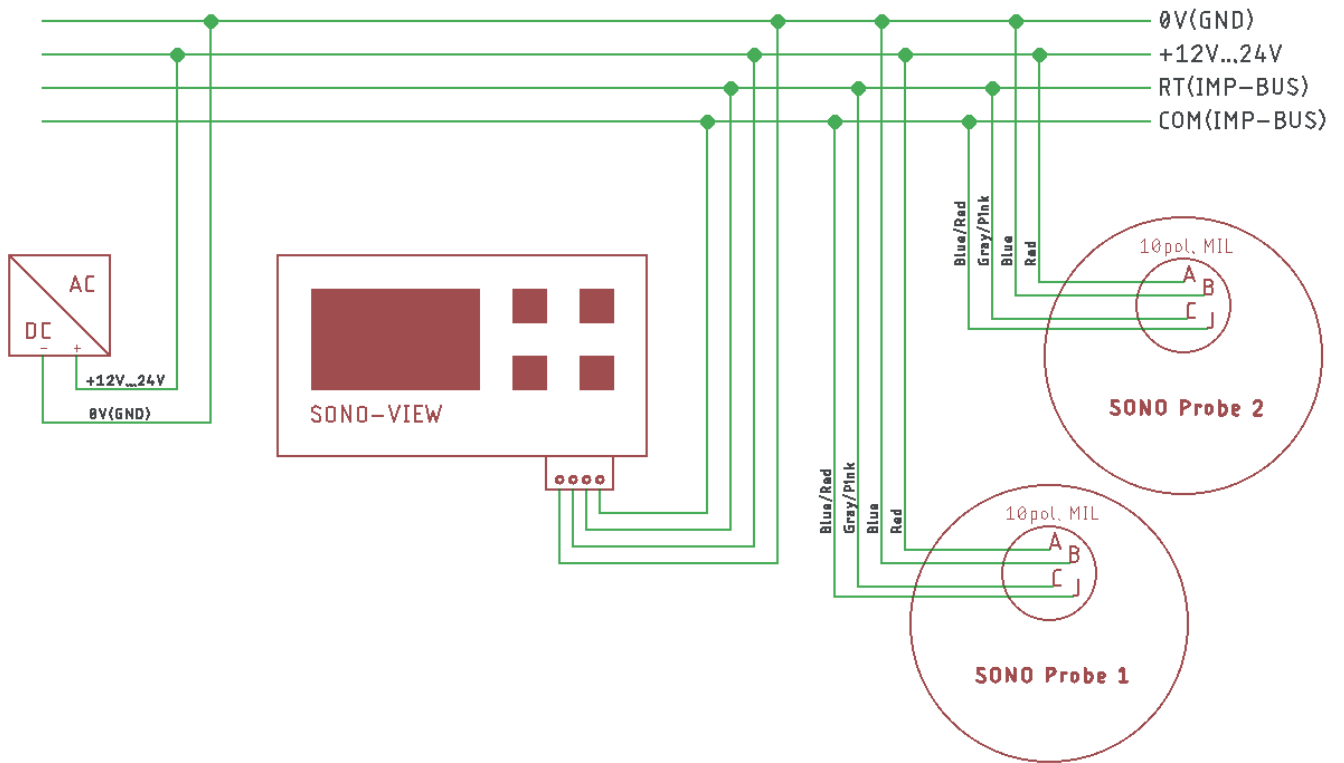

4 Operation

4.1 Initial and New Installation

At the initial connection to your probe-network, it is necessary to follow the installation procedure of the SONO-VIEW.



For this purpose, the device will scan the IMB bus for connected probes.

Initiate the installation with the button .

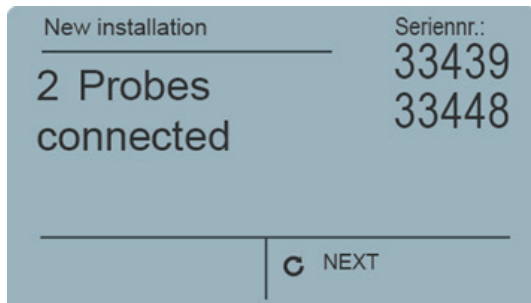

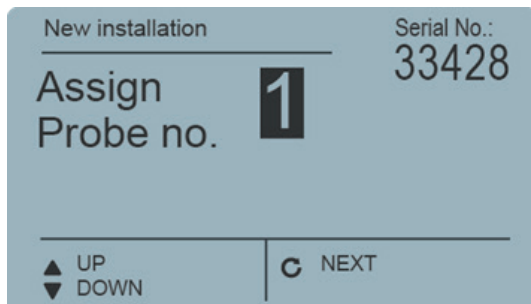

After an instant, the serial numbers of all connected probes are listed in the display.

Start the installation process with the button .



In order to maintain the clarity within the administration of the probes, the SONO-VIEW operates on the basis of assigned probe numbers (1...8).

These must be allocated to the detected serial numbers in the next step.

For each probe number, select a serial number using the  /  buttons and subsequently acknowledge the same with the button .

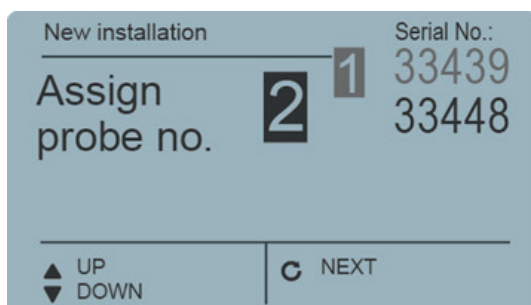

Repeat this procedure until all serial numbers have been allocated a probe number.

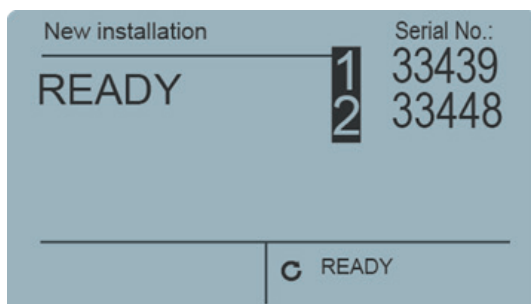

After completion of the above steps, all probe numbers will be presented once more together with the respectively allocated serial numbers in ascending order.

Complete the installation process with the button .

After completion of the installation process, the SONO-VIEW will re-start, verify the connected probes, and will immediately commence to call up the measurement values.

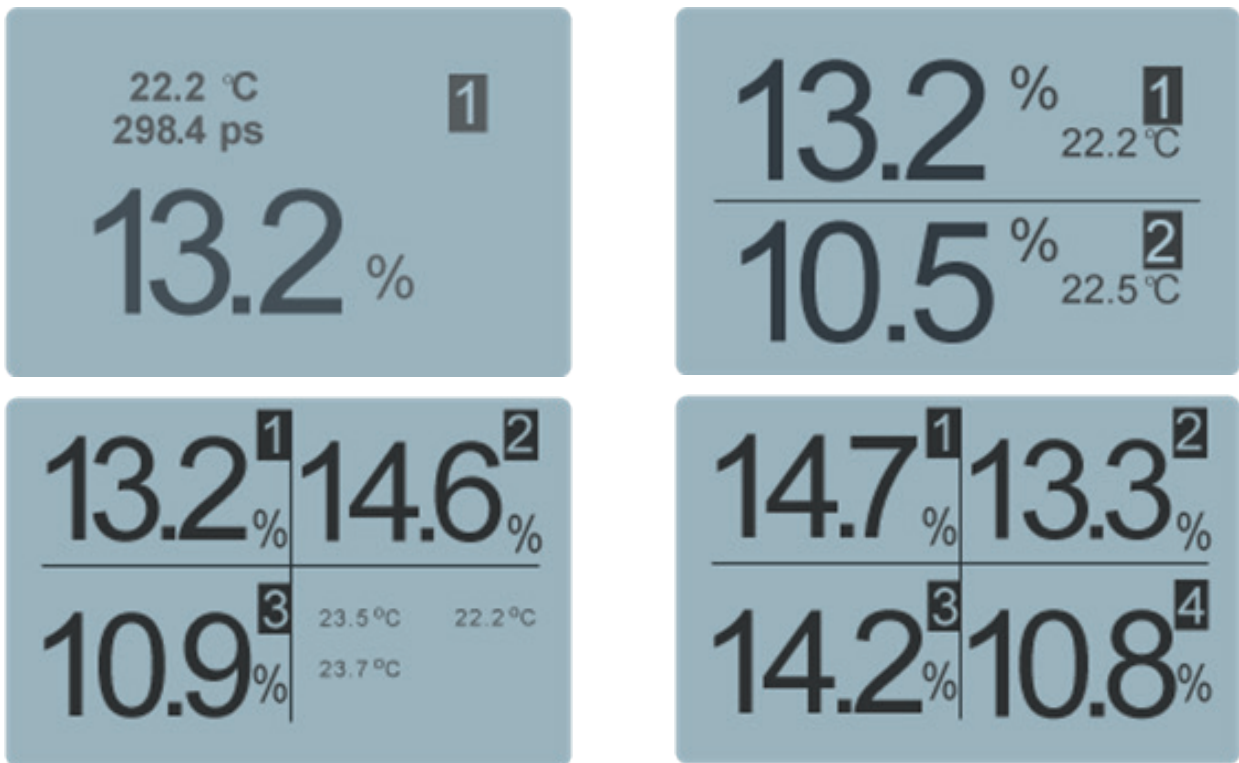

4.2 Measurement Value Display

The SONO-VIEW immediately commences to call up and display the measurement values after start-up. This is performed in a 500 ms cycle. Depending on how many probes are connected, from one to four, the following displays will be presented.



If between five and eight probes are connected, a second display with four values appears.

The moisture value in percent and the respective probe number is always presented. If two or three probes are connected, the temperature measured by the probe is additionally also presented. In the event that only one probe is connected, the calibrated radar run-time is also presented.

If more than one probe is connected to the SONO-VIEW, there is an option to change the display. For this purpose, press the buttons  / .

With each press, all connected probes are displayed one after the other as individual probes. If the last probe is displayed as a single probe, the next time the button is pressed, it will be displayed again the display of 4 probe values.

The probe number always appears in the upper right area of the display. If you remain on a display for a longer time, this display is set as the “default”. After a restart, the SONO-VIEW starts on the set measurement display.



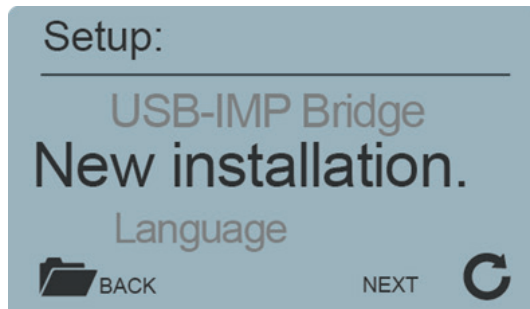

4.3 Settings

Actuate the button  while the measurement display is active and you will reach the setup menu. Here, you are enabled to perform various settings and call up information regarding the SONO-VIEW.



The setup menu features the following structure:

Setting	Description
New Installation	Enables a new detection of connected probes
Language	Setting of the language
Unit (Temp.)	Switch between °C and °F
LCD Contrast	Setting of the display contrast
Info	Serial number and further information regarding your SONO-VIEW
USB/IMP-Bridge	Enables the comfortable configuration of your probes via PC

Set the desired setting using the buttons  / . By actuating the button  you can subsequently enter the selected setting. Actuate the button  again in order to exit the setup menu.

4.3.1 New Installation

See Section 4.1 „Initial and New Installation“

4.3.2 Language

The selection of the language is performed with the buttons  / . By actuating the button  the selected language is set as the standard language.

To exit the menu item “Language”, actuate the button .



4.3.3 Unit (Temp.)

Use the  /  buttons to select the temperature unit.

4.3.4 LCD Contrast

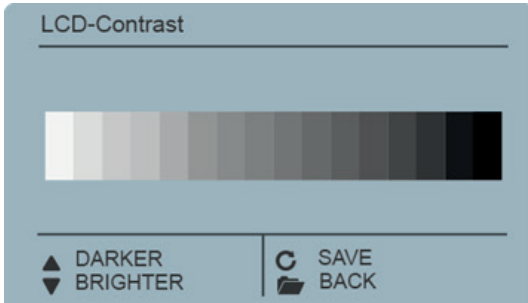
A bar containing a grey colour gradation will appear.



Set the contrast using the buttons  /  in a manner that enables you to recognise all grades.

Store the set value with the button .

To exit the menu item „LCD Contrast“, actuate the button .

4.3.5 Info

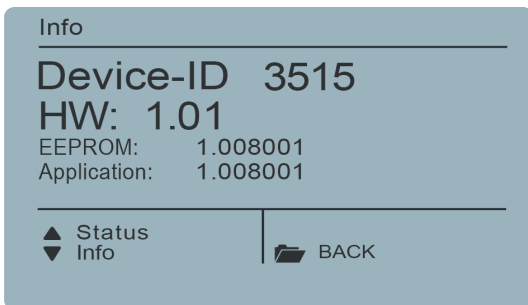

The device show the serial number, the HW-version, the IBT version, as well as the firmware version.

By press the button  the device will present further status information such as the currently connected probes and system voltage values.

To exit the menu item „Info“, actuate the button .

4.3.6 USB/IMP-Bridge

As soon as this menu item is called up, the SONO-VIEW changes into a transparent data mode. All data packets will be now redirected from the USB interface directly on to the IMP-bus and vice versa. This enables a comfortable configuration of the probes via a connected PC without the necessity of additional hardware.

For this purpose, please download the free software „SonoConfig“ as well as the respective operating instructions available on the IMKO-homepage www.imko.de/en.

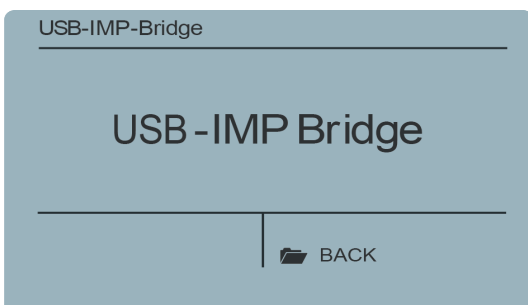



Connect the SONO-VIEW to the PC using the provided USB cable. The SONO-VIEW will connect with the PC as a virtual serial interface (COM-Port). The respectively required driver is usually automatically installed by all currently used Windows versions. Should the driver not be automatically installed, please download the driver under: <http://www.ftdichip.com/Drivers/VCP.htm>.

NOTE:

As long as the SONO-VIEW is in the USB-IMP-Bridge modus, no measurement values are queried by the probe. The probes however continue to measure and issue the measurement value at the analogue output.



Actuate the button  in order to exit the menu item „USB/IMP-Bridge“.

4.4 Probe Settings

The SONO-VIEW offers the option to comprehensively configure the connected probes even without PC. Settings such as offset displacements or the selection of a material-specific calibration can be simply adjusted with the buttons  / .

The menu “Probe Settings” respectively offers the following options:

Setting	Description
Sensor Info	Presents information regarding the connected probe
Material Calibration	Selection of a material-specific calibration, 1-point calibration and 2-point calibration
Offset balancing	Displacement of the measurement value
Average Mode	Setting of the method of averaging
Average Parameter	Setting of the parameters of the set averaging method
Basic balancing	„Zero Value“ calibration of the probe in ambient air
Analog parameters	Set the analog parameters
Analog simulation	Simulation of an analog value

To reach the probe settings, select the individual probe display mode for the probe intended for configuration in the measuring display using the  /  buttons (also see Item 4.2). By actuating the button  the probe setting of the currently used probe is called up.

NOTE:

It is only possible to configure one probe at a time. Should several probes require to be adjusted, the procedure must be respectively repeated for these other probes.

Attention:

Ensure that the correct probe is set before commencing with adjusting the parameters.

The SONO-VIEW offers the option to access the measuring parameters of the probe. Before adjusting any parameters, please inform yourself precisely in regard to the function of the same in the respective probe manual. Any performed changes may affect the measurement value, the accuracy, and the measuring rate.

4.4.1 Sensor Info

If this menu item is selected, various information of the probe is called up and displayed.

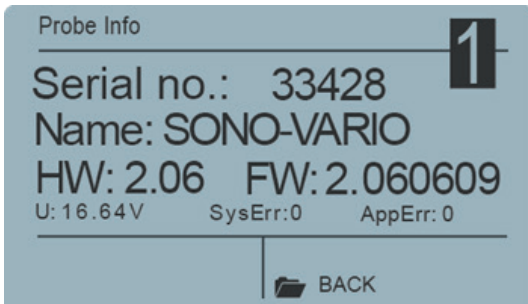



You can exit the menu item „Sensor Info” with the button .

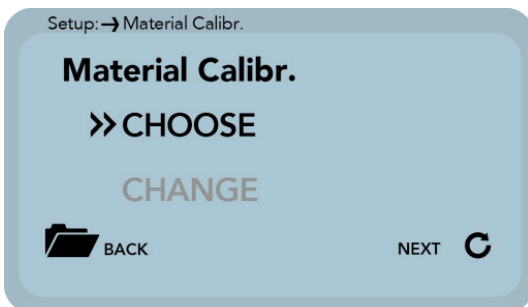

4.4.2 Material Calibration

The menu item „Material Calibration“ enables to adjust a material-specific calibration stored in the probe. This enables to significantly increase the accuracy of the measurement.

You also have the option of carrying out your own calibrations here in order to also be able to measure special materials.





After selecting the menu item "Material cal.", use the  /  buttons to "CHOOSE" one of the 15 stored material-specific calibrations or "CHANGE" to perform a new calibration on one of the 15 calibration memories.

The corresponding sub-point is selected with the key  and the key  leaves this menu point.

4.4.2.1 Choose

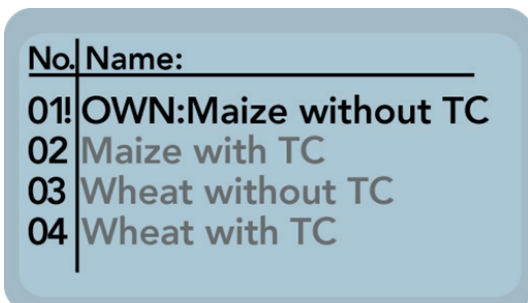
The sub-item "choose" allows you to select between up to 15 material-specific calibrations.



Use the  /  buttons to select between the material-specific calibrations. The "!" shows the current standard calibration.

Save the selected calibration with the button  as a standard in the probe.

By pressing the key  you can leave this sub-item "choose" again.

4.4.2.2 Change

The "CHANGE" sub-point allows you to perform a 1-point calibration or 2-point calibration.

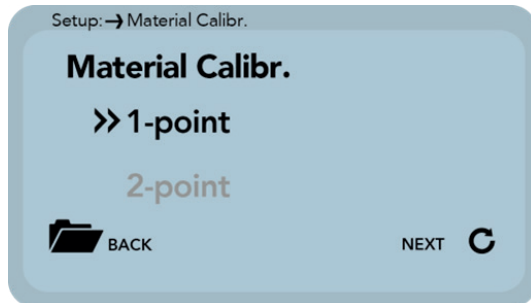

Use the / buttons to switch between 1-point calibration and 2-point calibration.

The corresponding procedure is executed with the key and the key is for finishing this procedure.

4.4.2.2.1 1-Point

With this material calibration option, a linear equation ($f(x)=mx+b$) is calculated with the dry density, a reference moisture content and the tp value (transit time of the radar signal) which can be measured or set at the point of the reference moisture content. Very good results are achieved with this linear calibration in most applications.

NOTE:

To perform a 1-point calibration, you need a material sample as well as the dry density of the material to be measured. The moisture value has to be determined with another method like kiln drying or similar, before activating this calibration procedure.

Procedure:

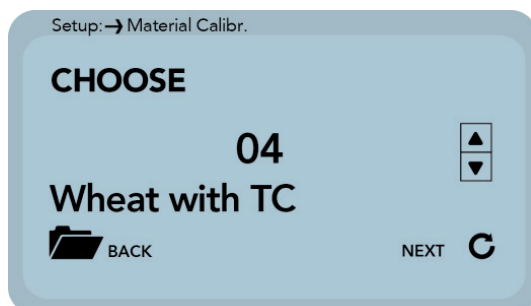

At the beginning of the calibration, the calibration memory (01 – 15) to be overwritten must be set using the / buttons.

Press the button to accept the setting and press the button to move to the previous item.

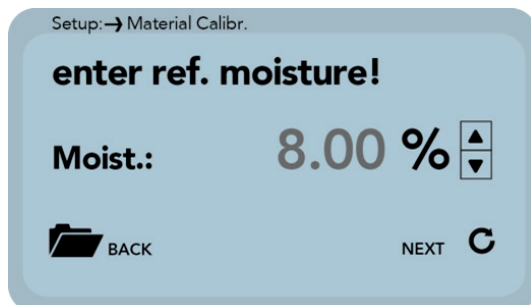

Then the percentage reference moisture of the measured material, must then be set with the / buttons.

Press the button to accept the setting and press the button to move to the previous item.

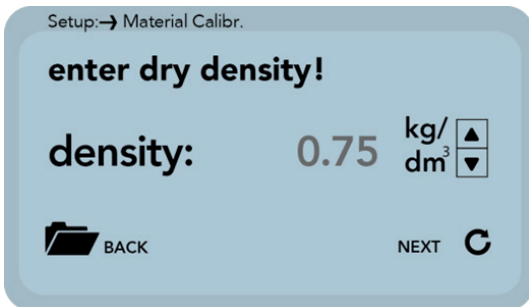

In the following step, the dry density of the material to be measured must be set with the / buttons.

Press the button to accept the setting and press the button to move to the previous item.

In the next step, the tp value (radar signal time) has to be determined by a measurement with the connected probe or by manual setting with pre-determined tp values.

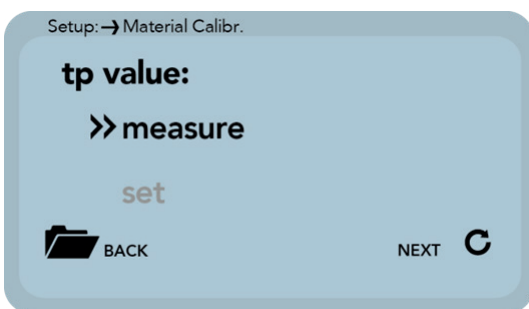

Use the / buttons to select between "Measure" and "Set".

The corresponding sub-point is selected with the key and the key can be used to switch to the previous point.

Measure tp:

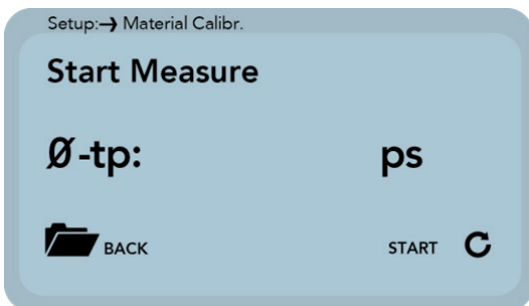

Press the key to start the tp measurement and press the key to move to the previous point.

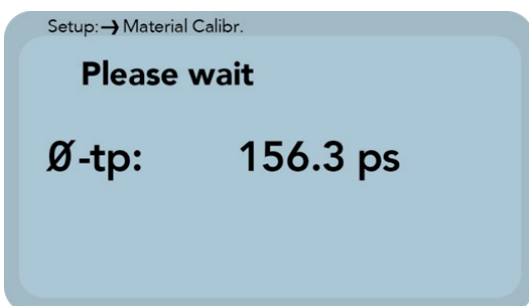

After starting the measurement with the key the mean value of 10 measured tp values is formed.

During this phase, the SONO-View does not respond to any input.

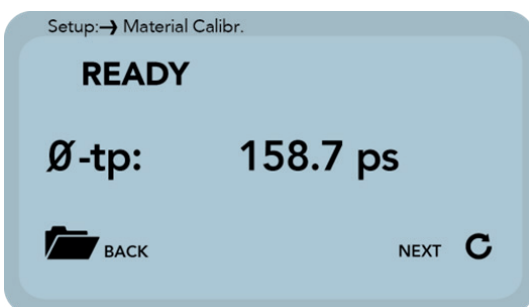

After completion of the measurement, the tp mean value is displayed.

Press the key to accept the measured value and press the key to move to the previous point.

Set tp



The tp value can be adjusted manually using the ▲ / ▼ buttons.

Press the button ⌂ to accept the setting and press the button ◀ to move to the previous item.

In the last step, the calibration settings can be saved with "Save" to the previously selected calibration memory location, or can be canceled with "Discard".

NOTE:

After performing "Save", the original material calibration is preceded by an "OWN:", this indicating that this is a specially prepared material calibration.

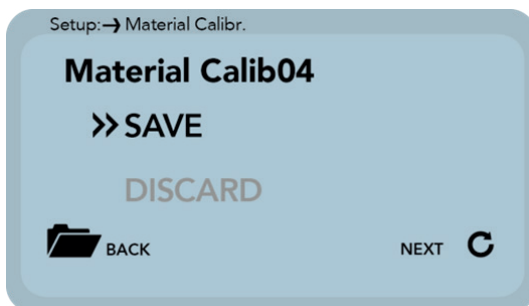

Use the ▲ / ▼ buttons to switch between "Save" and "Discard".

The corresponding sub-point is selected with the key ⌂ and the key ◀ can be used to switch to the previous point.

4.4.2.2.2 -2-Point

For the 2-point, a linear equation ($f(x) = mx + b$) can be calculated with two moisture values of a material and the corresponding tp values (running times of the radar signal) which are measured or set at the respective material moisture.

Very good results are achieved with this linear calibration in most applications.

NOTE:

In order to perform a 2-point material calibration, you need two material samples with different moisture values. Moisture values should be determined by another method like kiln drying or similar, before activating this calibration procedure. The sequence - "lower moisture value" (more dry material) and then - "upper moisture value" (moist material) must be observed.

Procedure:

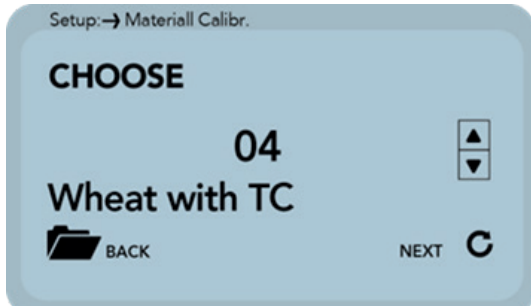

At the beginning of the calibration, the calibration memory (01 – 15) to be overwritten must be set using the / buttons.

Press the button to accept the setting and press the Button to move to the previous item.

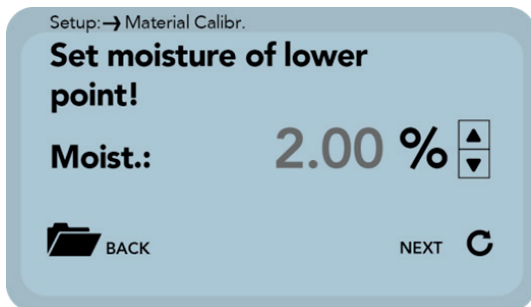

Subsequently, the percentage moisture value at the lower point of the material to be measured, must be set with the / buttons.

Press the button to accept the setting and press the button to move to the previous item.

In the next step, the tp value (radar signal time) has to be determined by a measurement with the connected probe at the lower moisture point or by manual setting with pre-determined tp values.

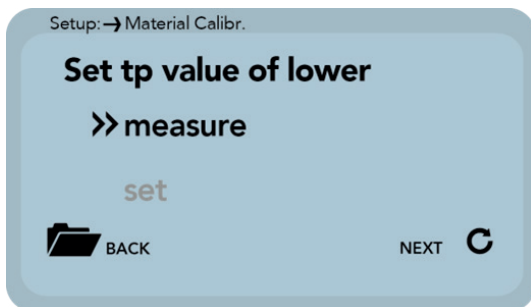

Use the / buttons to select between "Measure" and "Set".

The corresponding sub-point is selected with the key and the key can be used to switch to the previous point.

Measure tp:

See point „4.4.2.2.1“ Measure tp

Set:

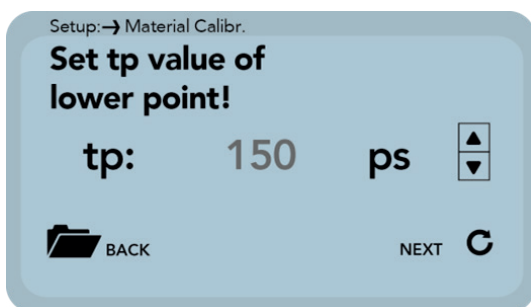

The tp value of the lower moisture point can be set manually using the / buttons.

Press the button to accept the setting and press the button to move to the previous item.

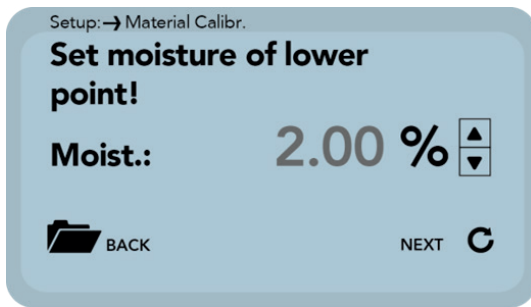

The percentage reference moisture of the upper point of the measured material, must then be set with the ▲ / ▼ buttons.

Press the button **C** to accept the setting and press the button **←** to move to the previous item.

The next step is to determine the tp value (radar signal time), of the upper moisture value, by a measurement (with the connected probe) or by manual setting.

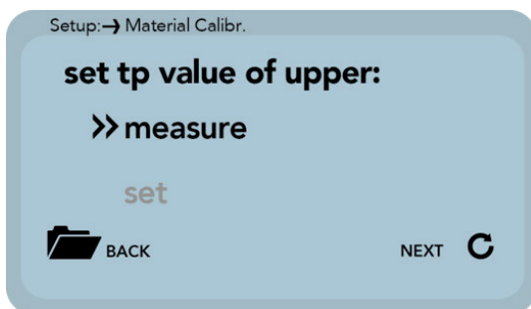

Use the ▲ / ▼ buttons to select between "Measure" and "Set".

The corresponding sub-point is selected with the key **C** and the key **←** can be used to switch to the previous point.

Measure tp:

See point „4.4.2.2.1“ Measure tp

Set:



The tp value for the upper moisture value can be adjusted manually using the ▲ / ▼ buttons.



Press the button **C** to accept the setting and press the button **←** to move to the previous item.

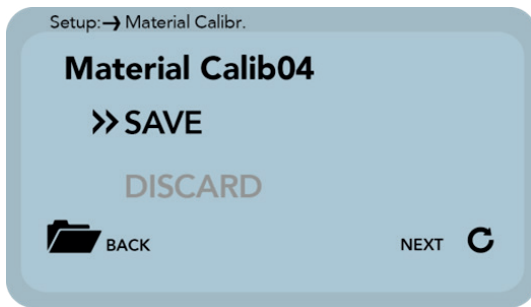

In the last step, the calibration settings can be saved with "Save" to the previously selected calibration memory location, or can be canceled with "Discard".

NOTE:

After performing "Save", the original material calibration is preceded by an "OWN:", indicating that this is a specially prepared material calibration.



Use the  /  buttons to switch between "Save" and "Discard".

The corresponding sub-point is selected with the key  and the key  can be used to switch to the previous point.

4.4.3 Offset Balancing

In order to compensate measurement errors e.g. due to density deviations in the material or due to the installation conditions, there is an option to perform a linear displacement of the measurement value. This is the purpose of this menu item. It is possible to displace the measurement value between -10 and +10 percent points. The set displacement is stored in the probe and will subsequently also affect the analogue output.

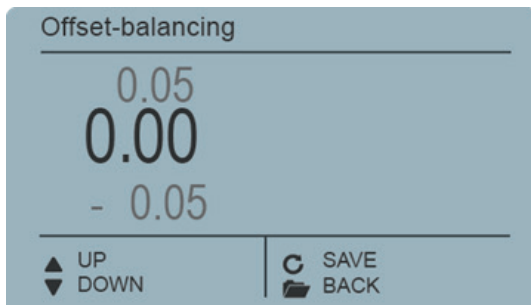

Adjust the offset to the desired value using the buttons  / .

Subsequently store the set value in the probe with the button .

You can exit this menu item with the button .

4.4.4 Averaging Mode

This menu item allows you to switch on or switch over a measurement averaging in the moisture probe. The IMKO moisture probes offer the following options:

Mode CC: (Cyclic Cumulated)

With automatic summation of a moisture quantity during one batch process.

Mode CH: (Cyclic Hold)

Similar to Mode CC but without summation.

Mode CH is recommended for applications in the construction industry. If the SONO-probe is installed under a silo flap, Mode CH can measure moisture when batch cycles are very short, down to 2 seconds. Mode CH executes an automatic filtering, e.g. if dripping water occurs.

Mode CA: (Cyclic Average Filter)

For relative short measuring processes with continual average value, filtering and an accuracy of up to 0.1%.

Mode CK: (Cyclic -Kalman-Filter)

For complex applications in mixers and dryers

Mode CS: (Cyclic-Successive)

For very short measuring processes (e.g. 5...20 seconds) without floating average and without filter functions, with internal up to 100 measurements per second and a cycle time of 250 milliseconds at the analogue output. Measurement mode CS can also be used for getting raw data from the SONO-probe without averaging and filtering.

Mode CF: (Cyclic Floating Average)

For continual average value with filtering and an accuracy of up to 0.1% for very slowly measuring processes, e.g. in fluidized bed dryers, conveyor belts, etc.

NOTE:

Please also refer to the information in your Probe User's Manual.

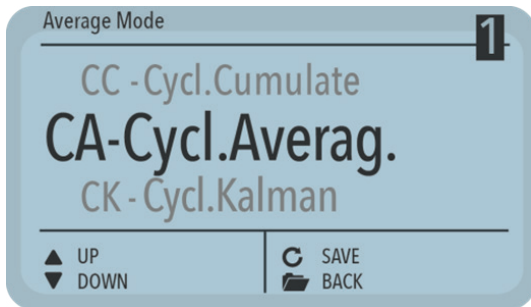

Use the / buttons to set the desired "Average Mode" and then set the mode as the default with the button

The setting is then stored in the probe.

Press the button to exit the "Average Mode" menu item.

4.4.5 Averaging Parameters

Depending on the set „Averaging Mode“, there are various „Average Parameters“ available for control purposes.

Averaging Mode	Available Parameters
CC – Cyclic Cumulate	Average Time
	Filter Upper Limit Offset
	Filter Lower Limit Offset
	Upper Limit Keep Time
	Lower Limit Keep Time
	Moisture Threshold
	No Material Delay
	Boost
	Offset
	Invalid Measure Count
CH – Cyclic Hold	Average Time
	Filter Upper Limit Offset
	Filter Lower Limit Offset
	Upper Limit Keep Time
	Lower Limit Keep Time
	Moisture Threshold
	No Material Delay
	Boost
	Offset
	Weight
Invalid Measure Count	

Averaging Mode	Available Parameters
CA – Cyclic Average	Average Time
	Filter Upper Limit Offset
	Filter Lower Limit Offset
	Upper Limit Keep Time
	Lower Limit Keep Time
	Invalid Measure Count
CK – Cyclic Kalman	Average Time
	Filter Upper Limit Offset
	Filter Lower Limit Offset
	Upper Limit Keep Time
	Lower Limit Keep Time
	Q-Parameter
	R-Parameter
	Kalman with Boost
	Boost
	Offset
Offset with Moist Average	
CS – Cyclic Successive	N/A
CF – Cyclic Floating	Average Time
	Filter Upper Limit Offset
	Filter Lower Limit Offset
	Upper Limit Keep Time
	Lower Limit Keep Time
	No Material Delay
	Boost
	Offset
	Invalid Measure Count

NOTE:



Please respectively also read the further information contained in your probe operator manual.

Attention:

Before adjusting a parameter, please precisely inform yourself in regard to the function of the same. Any performed change may affect the measurement value, the accuracy, and the measuring rate.

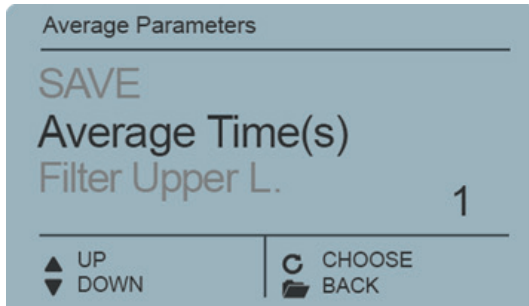
The parameters are dynamically enabled with the set „Average Parameter“.





The buttons  /  serve for the navigation between the individual parameters.

The current value of the selected parameter is presented in the lower right section of the display.

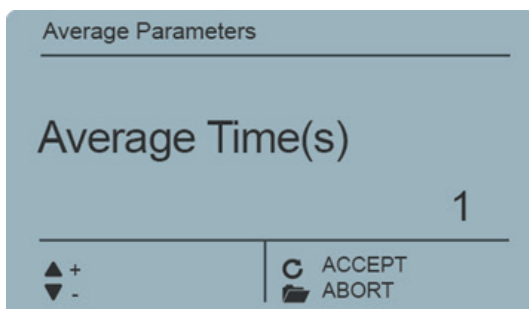
To change the value, press the button .





The value will now appear enlarged in the display. Adjust the value with the buttons  /  and subsequently assume the same with the button .

You also have the option to exit the entry with the button  without performing any change to the value.

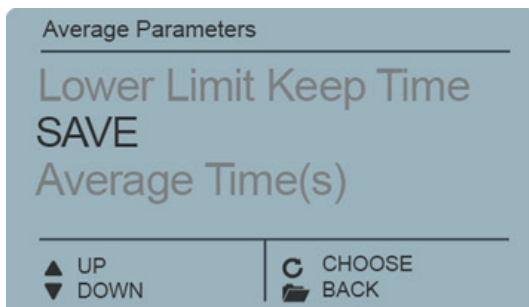

Repeat this procedure for all parameters intended for adjustment.



As soon as you have performed all adjustments as desired, select the item „Save“ and acknowledge the same with the button . Now, the parameters are written back into the probe and are immediately active.

You can exit the menu item „Average Parameters „with the button  without saving the same. Hereby, all performed changes are deleted!

NOTE:

Pressing the key  briefly will take you to the previous menu point. By pressing the key  for a long time, regardless of which material calibration sub-point is currently active, you return to the probe setting menu.

4.4.6 Basis Balancing

At the exchange of a sensor head, due to deviating cable lengths, it may be necessary to perform a basic balancing in air. Hereby, the moisture measurement value of the probe is re-aligned to the correct „Zero Value“.

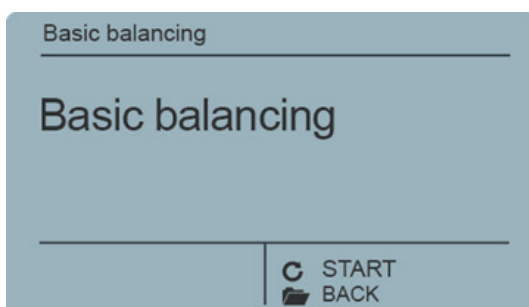

Press the button  in order to start the basic balancing. The balancing will be performed sub-sequently.

Attention:

In order to exclude the occurrence of a faulty air calibration, the sensor must be dry and free of any material during basic balancing.

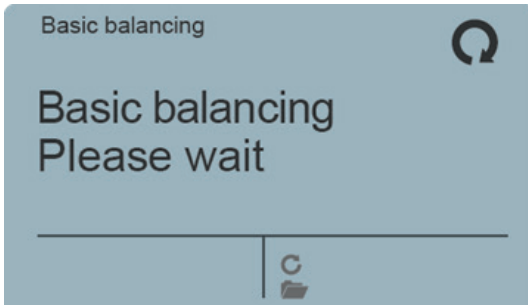

The notice „Please wait „will be generated in the display. The procedure lasts approximately 30 seconds.

4.4.7 Analog Parameter

This menu is used to configure the analog output of the probe.

Einstellung	Beschreibung
Analog signal	The analog signal output range can be set here. You can choose between 4..20mA / 0..20mA / 20..4 mA / 20..0mA
Analog version	The output values can be set here
Moist min	Settings of the minimum moisture value
Moist max	Settings of the maximum moisture value
Temp min	Settings of the minimum temperature value
Temp max	Settings of the maximum temperature value
RbC min	Settings of the minimum conductivity value
RbC max	Settings of the maximum conductivity value
Save	With Save, the settings are written back into the probe and are effective immediately

4.4.8 Analog Simulation

The analog output can be preset here to a fixed value for reason of alignment of an external reading (e.g. PLC).

5 Technical Data

Power Supply	+12 .. 24V DC / 0.7W
Operating Temperature	0 .. 50°C
Dimensions	145mm x 75mm x 34 mm
Weight	153g
Mounting	Cap Rail (optional)
Interfaces	IMP-Bus USB Mini-B (galvanically isolated)

6 Safety Notes

In this documentation, text points are highlighted, which require special attention.

DANGER:

The Warning Triangle with the exclamation mark warns you against personal injury or property damage.



Intended Use

Sensors and measuring systems of IMKO GmbH may only be used for the purpose described, taking into account the technical data. Misuse and use of the equipment other than for its intended purpose are not eligible. The function and operational safety of a sensor or measuring system can only be guaranteed if the general safety precautions, national regulations and the special safety instructions in this operating manual are observed during use.

The moisture sensors and measuring systems of IMKO GmbH are used to measure moisture according to the measuring purpose and measuring range defined and defined in the technical data. Only adherence to the instructions described in the manual is regarded as intended use. The manual describes the connection, use and maintenance of IMKO sensors and IMKO measuring systems. Read the manual before connecting and operating a sensor or measuring system. The manual is part of the product and must be kept close to the sensor or measuring system

Impairment of safety

The sensor or the measuring system has been designed and tested in accordance with EN 61010 safety regulations for electronic measuring instruments and has left the factory in a safe and safe condition. If the sensor or the measuring system can no longer be operated safely, it must be put out of operation and secured by means of marking before further commissioning. In case of doubt, the sensor or the measuring system must be sent to the manufacturer or his contractual partner for repair or maintenance.

Modifications

For safety reasons, it is not permitted to carry out any modifications or modifications to the sensor or the measuring system without the consent of the manufacturer. The opening of the sensor or hand-held meter, adjustment and repair work, as well as all maintenance work other than the work described in the manual may only be carried out by a specialist authorized by IMKO. The sensor or the measuring system must be disconnected from the power supply before installation or maintenance work. Do not open or repair the hand-held unit and the power supply!

Hazard Warnings

Danger due to improper operation. The sensor or the measuring system may only be operated by instructed personnel. The operating personnel must have read and understood the operating instructions.

Danger by electricity

The hand-held meter must not be immersed in water or other liquids. The sensor is insensitive to moisture contained in the typically measured products. Only connect the hand-held meter to a properly installed outlet with the supplied voltage supply cable, the voltage of which corresponds to the technical data.

For the operation of this device, a power supply is required which must be located in the immediate environment or less than 3 meters and meets the following standards: DIN EN 61000-6-2 (interference immunity industry) and DIN EN 61000-6-4 (emission industry).

Only operate the meter with the supplied original accessories. If you need additional accessories or replacement, please contact the manufacturer.

Do not use the meter in following case:

- if the measuring instrument, sensor, plug-in power supply or accessories are damaged,
- the sensor or the measuring system does not operate as intended,
- the power cord or plug is damaged,
- the sensor or the measuring system has fallen down.

Unplug the power supply from the wall outlet in following case:

- if you do not use the sensor or the measuring system for an extended period of time,
- before cleaning, unpacking or changing the sensor or the measuring system,
- if you are working inside the sensor or measuring instrument, e.g. connect devices,
- if a fault occurs during operation,
- during thunderstorms.

Caution - Property damage

Ensure that there is a sufficient distance to strong heat sources such as heating plates, heating pipes. Disconnect the sensor or handheld device from other devices before relocating or transporting it. Disconnect the connectors on the device.

Do not use aggressive chemical cleaning agents, scouring agents, hard sponges or the like

The user must make sure, not to be charged with static electricity. In case of a malfunction due to static electricity, please reboot the device.

The device is not designed for use in residence places. In rare cases radio reception may be disturbed.

Attention

This device is a service device which must be installed in a control cabinet.

7 Notes

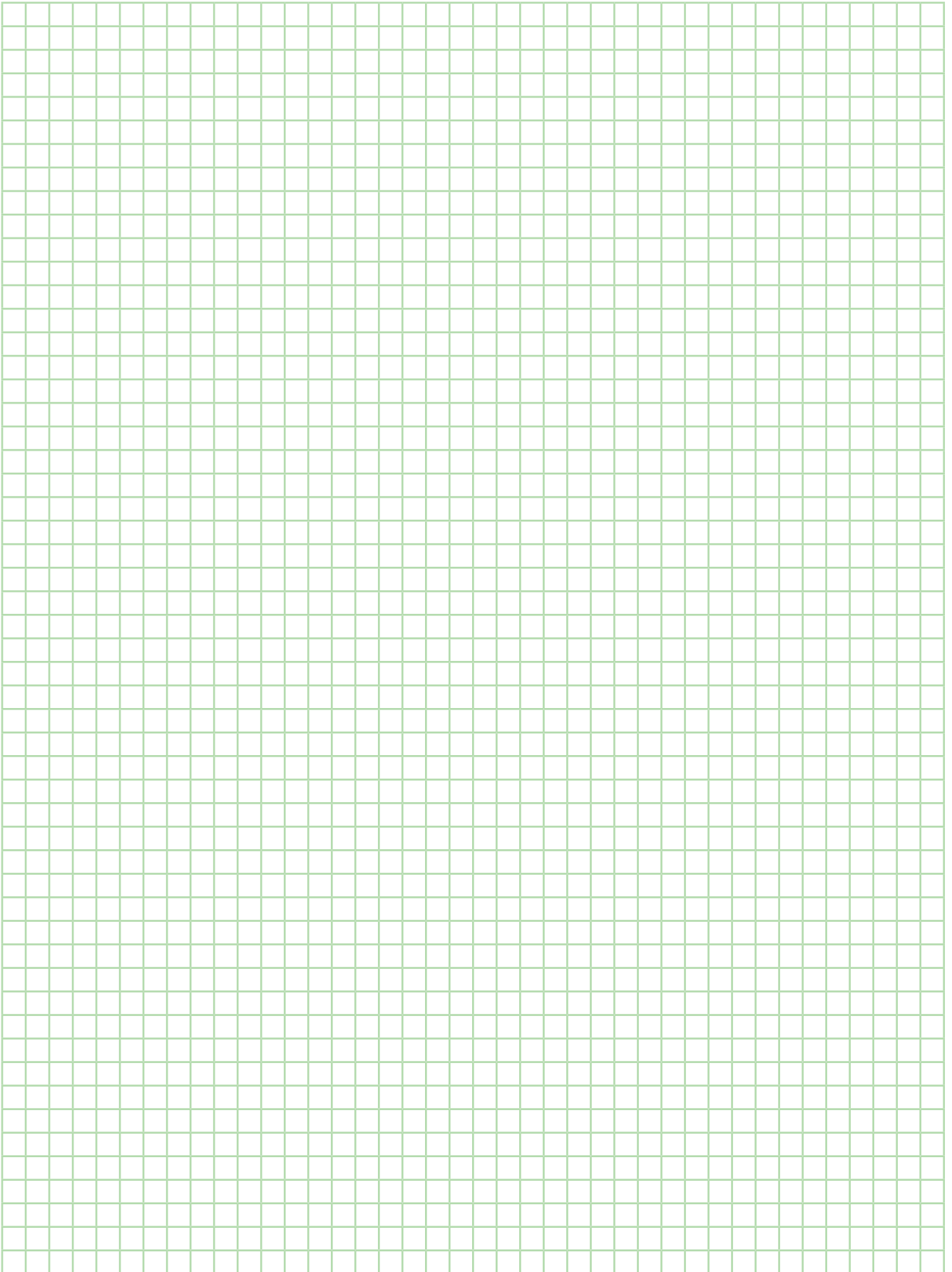

Contact

IMKO Micromodultechnik GmbH
Am Reutgraben 2
76275 Ettlingen
Germany

Tel +49 7243 5921 0
Fax +49 7243 5921 40
info@imko.de

www.imko.de/en

