

- **Reliable**
- **Non-Contact**
- **Narrow Beam Technology**

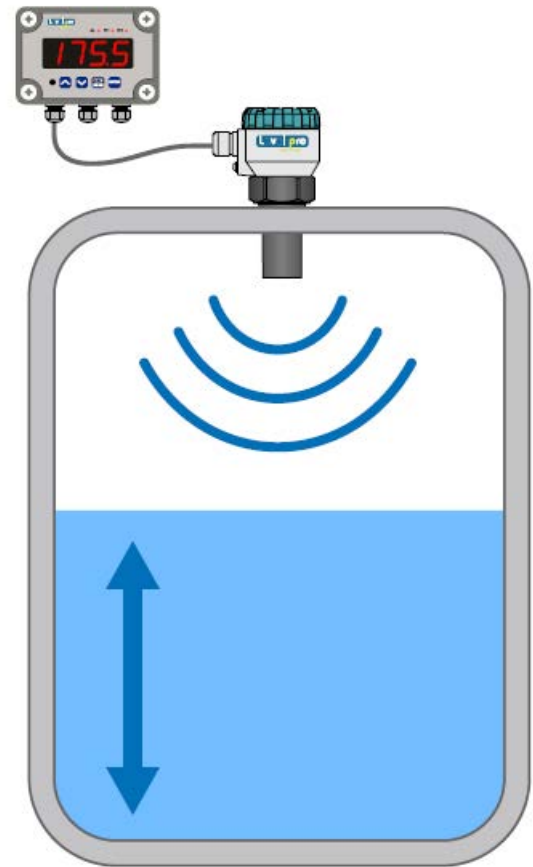

FEATURES

- Accurate Non-Contact Continuous Level Measurement of liquids | Tanks | Sumps | Ranges up to 65 Feet
- Quick View Display
- Simple to Program | Easy Adjustment
- False Echoes Elimination | (Self Teaching)
- Automatic Temperature Compensation
- Explosion Proof | Option Available
- Analog Current output (4-20mA) with HART® protocol or output RS-485 Modbus
- Bright Yellow LED Display
- Lock-Out Feature

The UltraPro Ultrasonic level Sensors are 2-Wire loop powered sensors designed provide reliable accurate level measurement, flow monitoring, and volume of liquids in tanks, pits, sumps and open channels. The UltraPro series are very reliable and offer both 4-20mA analog output with HART® protocol or output RS-485 Modbus.

Key Applications : Chemical Storage Tanks | Waste Sumps | Bulk Storage | Tanker Truck | Day Tank | Process Tank | Neutralization Tank | Open Channel | Chemical Feed and Clarifier Applications. The UltraPro Series are designed to work with most types of remote instrumentation and provide enhanced functionality such as remote displays and remote monitoring solutions.

TECHNICAL SPECIFICATIONS

Display type		LED
Resolution		128 x 64 pixel
Character height Number of digits - measured value		9 mm 5 Digits
Display color		Yellow
Buttons		Membrane Type
Ambient temperature range		-40 ... +70 °C
Weight		46 g
Measuring range 1)	UPS-1000_-01-_ UPS-1000_-02-_ UPS-1000_-06-_ UPS-1000_-10-_ UPS-1000_-20-	0.1 ... 1 m 0.2 ... 2 m 0.2 ... 6 m 0.4 ... 10 m 0.5 ... 20 m
Supply voltage	UPS-1000N-_-_-_ UPS-1000Xi-_-_-I	18 ... 36VDC 18 ... 30VDC
Current supply	UPS-1000N(Xi)-_-_-	4 ... 20mA max. 22mA
Output	UPS-1000_-_-_-I UPS-1000_-_-_-M	4 ... 20mA (Limit values 3.9 ... 20.5mA), HART® RS-485 with protocol Modbus RTU
Current output UPS-500_-_-_-I Voltage output UPS-500N-_-_-U Modbus output UPS-500N-_-_-M		4 ... 20mA (limit values 3.9 ... 20.5mA) 0 ... 10V (limit values 0 ... 10.2V) Modbus RTU protocol
Resolution		< 1 mm
Accuracy (within the total range)	UPS-1000_-01- in area 0,1-0,2 m 0,2-1,0 m UPS-1000_-02-;-06 UPS-1000_-10-;-20	0.3 % 0.2 % 0.15 % 0.2 %
Temperature error		Max. 0,04% K
Beamwidth (-3 dB)	UPS-1000_-01-_-; 02-_-; 10-_ UPS-1000_-06-_- UPS-1000_-20-_-	10° 14° 12°
Ambient temperature range	UPS-1000_-01-_-; 02-_-; 06-_ UPS-1000_-10-_-; 20-_-	-30 ... +70 °C -30 ... +60 °C
Measuring period	UPS-1000_-01-_-; 02-_ UPS-1000_-06-_-; 10-_ UPS-1000_-20-_- UPS-1000_-_-_-M	0,5 s 1,2 s 5,0 s adjustable via Modbus RTU
Averaging (can be modified according to agreement)	ULM-1000_-_-_-_ ULM-1000_-_-_-M	4 measurement adjustable via Modbus RTU
Short time temperature stress resistance		+90° C 1 hod.
Max. operation overpressure (on transmission surface)		0,1 MPa
Max. internal values 2) (for the Xi version only)		Ui=30 V DC; Ii=132 mA; Pi=0,99 W; Ci=370 nF; Li=0,9 mH
Failure indication	echo failure – basic mode echo failure – inverse mode level in dead zone – basic mode level in dead zone – inverse mode	3,75 mA (0V) 22 mA (10,5V) 22 mA (10,5V) 3,75 mA (0V)
Protection class		IP67
Recommended cable		PVC 2 x 0,75 mm ² (3 x 0,5 mm ²)
Maximal current output load resistance	at U = 24VDC at U = 22VDC at U = 20VDC	R _{max} = 270 Ω R _{max} = 180 Ω R _{max} = 90 Ω
Minimal voltage output load resistance		R _{min} > 1 k Ω
Delay between supply power rise time and first measurement	UPS-1000_-01-_-; 02-_-; 06-_ UPS-1000_-10-_-; 20-_-	5 s 9 s
Process connection	UPS-1000_-01-_ UPS-1000_-02-_ UPS-1000_-06-_ UPS-1000_-10-_ UPS-1000_-20-_ aluminium alloy flange	thread ¾" thread 1" thread 1½" thread 2¼"
Weight	UPS-1000_-01-_ UPS-1000_-02-_ UPS-1000_-06-_ UPS-1000_-10-_ UPS-1000_-20-_-	0,20 kg 0,20 kg 0,25 kg 0,65 kg 2,80 kg

Mounting Recommendation

Recommended installation

Installation distance from the tank wall

c - measuring range
d - min. distance from tank wall

UPS-1000_-02;10	d > 1/12 c (min. 200 mm)
UPS-1000_-06	d > 1/8 c (min. 200 mm)
UPS-1000_-20	d > 1/10 c (min. 200 mm)

Maximum level distance

Electrical Connection

Wiring diagram of the level meter with current output UPS-1000_-_-_-I

Wiring diagram of the level meter with Modbus UPS 1000_-_-_-M

Inside view of screw terminals of the level meter with current output UPS-1000_-_-_-I

Inside view of screw terminals of the level meter with Modbus UPS-1000_-_-_-M

When measuring bulk solids or applications where foam may be present, the measurement range is reduced due to absorption of acoustic waves shortening of the measuring range occurs by up to 50%. We therefore recommend selecting a level meter with a greater range than the maximum range to measure the medium. It is also recommended to use the directional horn (option) which better concentrates the acoustic energy while preserving the same beam angle, and improves the sensitivity when receiving the reflected echo.

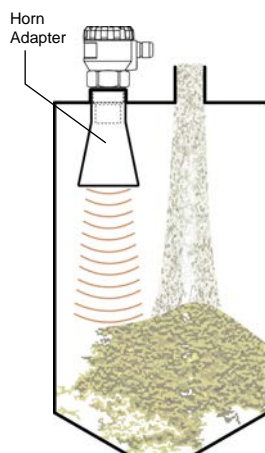

Order Code

UPS - 1000 [] - [] - [] - [] - [] - []

- Add Horn - H
- Set-up elements : D – basic version with display
L – without display, metal lid
- Output type : I – current output
M – RS-485 (Modbus RTU)
- Process connection : NPT – thread F – flange
- Maximum Range : 02 – 0,15 ... 2 m
06 – 0,25 ... 6 m
10 – 0,4 ... 10 m
20 – 0,5 ... 20 m
- Performance : N – Normal – usable in non-explosive areas only
Xi – Ex. proof – suitable for explosive areas

DIMENSIONS DRAWINGS

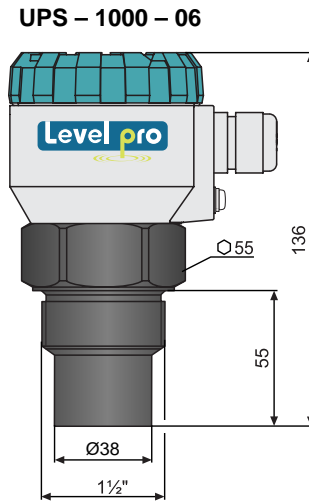
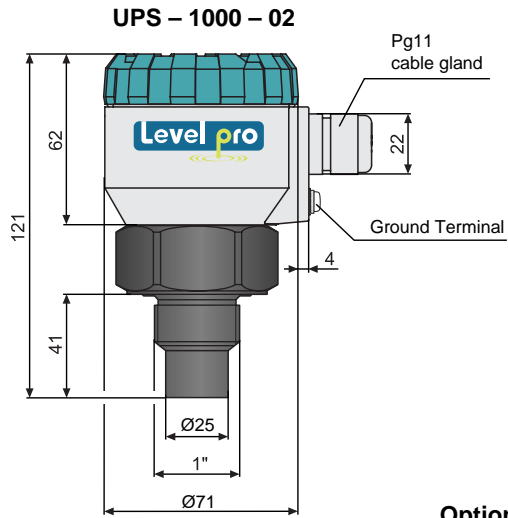

Optional UPS-1000 with protective connector

