

## Differential pressure transmitter PASCAL Ci4 Delta P for general application Type series CI4300



### Application area

- General process engineering
- Chemical and petrochemical industry
- General process technology

### Features

- Differential pressure transmitter with metallic diaphragm
- Stainless steel case in sturdy design, degree of protection IP 65/67
- Accuracy 0.1 %
- High-resolution graphic display with Intuitive 4-button operation and backlight
- Comprehensive parameterising functions
- Comprehensive simulation and diagnostic functions
- Quick access to device data
- Development according to SIL2
- Nominal range 0.25 bar to 40 bar
- Turndown up to 100:1
- Measuring rate up to 100 Hz
- Output signal 4...20 mA with HART® protocol
- Configuration memory
- Digital communication via PDM, FDT/DTM, 375/475 Field Communicator
- Output functions: linear, invers, square root, table function with up to 64 support points
- Media temperature -40...100 °C
- Wetted parts stainless steel
- Approved according to NAMUR 95
- EAC declaration (upon request)

### Options

- Approvals/Certificates
  - Explosion protection for gases and dust
  - Classification per SIL2
  - Certificate of measuring equipment for Russian Federation
  - Calibration certificate per DIN EN 10204
- Removable display and control unit
- Degree of protection IP 69K

### Application

The digital differential pressure transmitter PASCAL Ci4 Delta P for general application is suitable for level measurement and filter monitoring in chemical/petrochemical and in general process engineering.

## Technical data

### Measuring ranges

Up to a turndown of 100:1 the measuring span can be freely selected.

Nominal range	Measuring span		Overload capacity		Static excess pressure both sides
	min. span	max. span	plus-side	minus-side	
-0.25...0.25 bar	0.0025 bar	0.5 bar	10 bar	5 bar	75 bar
-1...1 bar	0.01 bar	2 bar	20 bar	10 bar	75 bar
-1...4 bar	0.04 bar	5 bar	50 bar	25 bar	75 bar
-1...16 bar	0.16 bar	17 bar	100 bar	75 bar	100 bar
-1...40 bar	0.4 bar	41 bar	100 bar	75 bar	100 bar

### Constructional design / case

Design:	Two-chamber case, continuously rotatable by $\pm 170^\circ$ Case surface blasted
Material case:	<ul style="list-style-type: none"> <li>■ Stainless steel mat.no. 1.4301/1.4305 (304/303)</li> <li>■ Stainless steel mat.no. 1.4404 (316L)</li> </ul>
Material front cover:	<ul style="list-style-type: none"> <li>■ Stainless steel mat.no. 1.4305 (303)</li> <li>■ Stainless steel mat.no. 1.4404 (316L)</li> <li>■ Polypropylene, black</li> </ul>
Gaskets:	Silicone / NBR
Degree of protection per EN 60529:	IP 65 / IP 67 Option: IP 69K
Climatic category per EN 60721 3-4:	4K4H
Vibration resistance per EN 61298-3:	10...60 Hz: $\pm 0.35$ mm 60...1000 Hz: 5 g
Material window:	<ul style="list-style-type: none"> <li>■ Macrolon</li> <li>■ Non-splintering glass (requires front cover of stainless steel)</li> </ul>
Elec. connection:	<ul style="list-style-type: none"> <li>■ Circular connector M12</li> <li>■ Cable gland M16x1.5, PA black</li> <li>■ Cable gland M16x1.5, stainless steel</li> <li>■ Cable gland M20x1.5, PA black</li> <li>■ Cable gland M20x1.5, stainless steel</li> <li>■ 1/2" NPT, PA black</li> </ul> <p>Further connections upon request</p>
Terminal blocks:	<ul style="list-style-type: none"> <li>■ Spring clamp terminals up to 1.5 mm<sup>2</sup></li> <li>■ Pole terminals up to 2.5 mm<sup>2</sup></li> <li>■ Screw terminals up to 2.5 mm<sup>2</sup></li> </ul>
Weight:	approx. 1.4 kg (without process connection)
Type plate:	Laser marking

### Process connection

Design:	Process flange with connection dimension per DIN EN 61518 <ul style="list-style-type: none"> <li>■ Process connection 1/4 – 18 NPT Mounting thread 7/16 – 20 UNF</li> <li>■ Process connection 1/2 – 14 NPT via oval flange (see accessories)</li> </ul>
	Process flange incl. 1/4" NPT sealing plug, alternative with vent valve. The process flange is rotatable. Further process connections upon request.

### Material wetted parts

Process flange:	Stainless steel, mat.-no. 1.4408
Diaphragm:	Stainless steel, mat.-no. 1.4404/1.4435 (316L)
Gasket:	FKM Viton
Ventilation valve:	Stainless steel, mat.-no. 1.4404 (316L)
Sealing plug:	Stainless steel, mat.-no. 1.4571 (316Ti) Option: stainless steel 316L

### Measuring system

Sensor:	Piezoresistive measuring element
System filling:	Synthetic oil FD1, free of silicone, FDA compliant

### Accuracy

Reference cond. per EN 61298-1:	$T_U = \text{const. (15...25) } ^\circ\text{C}$ $\varphi = \text{const. (45...75) \% r.F.}$ $p_U = \text{const. (860...1060) mbar}$ $U_B = 24 \text{ V DC } (\pm 3 \text{ V DC})$ $R_B = 50 \Omega, \text{ HART: } 250 \Omega$ Ground connected $MBA = 0 \text{ bar}$
---------------------------------	---

Calibration position:	Process connection bottom: vertical
-----------------------	-------------------------------------

Deviation of characteristic:	Refer to the adjusted measuring span (Limit point method per DIN 16086) <b>Nominal range 1-40 bar</b> Turndown 5:1      0.1 % Turndown > 5:1    0.02 % x TD <b>Nominal range 0.25 bar</b> Turndown 5:1      0.15 % Turndown > 5:1    0.03 % x TD
Long-term drift:	Refer to nominal range ≤ 0.1 %/year
Operational availability	< 12 s
Response time $t_{90}$ at current output	for 20 Hz measuring rate: typically 120 ms for 100 Hz measuring rate: typically 50 ms
Temperature influence, case:	Refer to nominal range <b>Ambient temperature -20...80 °C:</b> Nominal range 1-40 bar      0.1 %/10K, max. 0.3 % Nominal range 0.25 bar      0.15 %/10K, max. 0.4 % <b>Ambient temperature -40...-20 °C:</b> Typical 0.2 %/10K
Influence static pressure:	Refer to nominal range 0.25 bar      0.12 % x stat. pressure [bar] x TD 1 bar          0.03 % x stat. pressure [bar] x TD 4 bar          0.02 % x stat. pressure [bar] x TD 16 bar        0.002 % x stat. pressure [bar] x TD 40 bar        0.001 % x stat. pressure [bar] x TD

## Indication

Display:	<ul style="list-style-type: none"> <li>■ High-resolution graphic display with backlight</li> <li>■ 4-button operation</li> <li>■ Freely configurable display modes</li> <li>■ continuously rotatable by ± 170 (detent every 90°)</li> <li>■ Optional: Remote display and control unit, can be used up to 10 m away from measuring point</li> </ul>
Configuration memory:	<ul style="list-style-type: none"> <li>■ All parameterisation data can be copied from the device into the configuration memory in the display module. The data is permanently stored there, even in the event of power failure.</li> <li>■ The parameters can be transferred simply and quickly to other devices.</li> </ul>

## Output

Signal:	2-wire technology	4...20 mA
	Lower limit	3.8...4 mA
	Upper limit	20...21 mA
	Lower alarm current	< 3.6 mA
	Upper alarm current	> 21 mA
	Current limitation	22 mA
	Digital communication:	HART® protocol, version 7
	Device driver:	
	<ul style="list-style-type: none"> <li>■ EDD für SIMATIC PDM</li> <li>■ DTM for PACTware or compatible systems (FDT compliance)</li> <li>■ EDD for 375 / 475 Field Communicator</li> </ul>	
Function:	<ul style="list-style-type: none"> <li>■ linear</li> <li>■ inverse response</li> <li>■ by square root</li> <li>■ table function with up to 64 support points</li> </ul>	
Turndown:	Max. 100:1	
Damping:	0...999.9 s selectable in steps of 0.1 s	
Measuring rate:	20 Hz, switchable to 100 Hz	
Resolution:	1 µA	
Current sensing func.:	3.55...21.5 mA selectable in steps of 0.001 mA	
Load R:	$R \leq (U-12V \text{ DC})/0.022 \text{ A} [\Omega]$ U = supply voltage for HART® communication $R \geq 230 \Omega$	

## Supply voltage

Functional range:	12...30 V DC, protected against polarity reversal
Ripple:	< 5 %

## Temperature ranges

Ambient:	-40...80 °C (Display visibility is limited at temperatures below -30 °C)
Media:	-40...100 °C
Storage:	-40...80 °C

## Tests and certificates

### Ex approvals

ATEX: TÜV 13 ATEX 120264 X  
Ⓢ II 1/2G Ex ia IIC TX Ga/Gb  
Ⓢ II 1/2D Ex ia IIIC Txx °C Da/Db  
Ⓢ II 2G Ex ia IIC TX Gb  
Ⓢ II 2D Ex ia IIIC Txx °C Db

IECEX: IECEX TUN 13.0018X  
Ex ia IIC TX Ga/Gb  
Ex ia IIIC Txx °C Da/Db  
Ex ia IIC TX Gb  
Ex ia IIIC Txx °C Db

For more detailed information see Ex Safety Instruction XA\_011.

EMC : per EN 61326-1, NAMUR NE21

SIL 2: Functional safety per EN 61508, classification per SIL2  
For detailed information see SIL instruction SA\_001

NAMUR: Approved according to NE95,  
Test report TP14033 available upon request

- EAC declaration upon request
- Certificate of measuring equipment for Russian Federation

## Parameterisation, simulation and adjustment

### Parameterisation

Parameter	Values	Default setting
<b>Device</b>		
device ID	16 digits, freely selectable	LABOM PASCAL Ci4
lower range value	at any value within nominal range	0 bar
upper range value	at any value within nominal range	end of nominal range
measuring rate	20 Hz, 100 Hz	20 Hz
damping	0.0...999.9 s	0.0 s
<b>Display and control unit</b>		
pressure unit	mbar, bar, Pa, hPa, kPa, MPa, g/cm <sup>2</sup> , kg/cm <sup>2</sup> , psi, atm, torr, mmH <sub>2</sub> O, mH <sub>2</sub> O, inH <sub>2</sub> O, ftH <sub>2</sub> O, mmHg, inHg	bar
temperature unit	°C, °F, °R, K	°C
lighting	on, off	on
language	English, German	German
	English, Chinese	as ordered
	English, Spanish, French	as ordered
	English, Polish, German	as ordered
	English, Turkish, German	as ordered
decimal point	auto, x.xxxx, xx.xxx, xxx.xx, xxxx.x, xxxxx	auto
display mode	five values, four values, three values, two values, big display	four values
main value	pressure, current in %, current in mA	pressure
secondary values	pressure, current in %, current in mA, sensor temperature, device ID, HART-TAG, HART-Descriptor, <empty>	current in %, current in mA, device ID
<b>Current output</b>		
output function	linear, inverse response, by square root, table function	linear
lower current limit	3.8...4.0 mA	3.8 mA
upper current limit	20...21 mA	20.5 mA
alarm current	low (<3.6 mA), high (> 21.0 mA)	low (<3.6 mA)
position correction (mounting position)	on, off	off
<b>Maintenance counter</b>		
maintenance interval	0...9999 days	0 days
status	on, off	off
<b>HART data</b>		
HART address	0...63	0
number of response preambels	5...20	5
current mode	proportional, constant	proportional

### Diagnostic functions

Self- diagnosis	Description	Value range
RAM-Test	Permanent check of the read/write memory	/
ROM-Test	Permanent check of the checksum via the program memory	/
Bridge circuit test	Permanent check of the bridge circuit	/
CRC parameterisation test	Permanent check of the checksum via the parameter memory	/
Electronics temperature monitoring	Permanent check of the electronics temperature	/
<b>Process diagnostics</b>		
Maintenance timer	Check of the maintenance cycles	/
Operating hours counter	Capture of operating hours	/
Min/Max values	Check of minimum and maximum process pressure and sensor temperature	/
<b>Measuring circuit diagnostics</b>		
loop-test	Setting of a fixed current value at the output	3,55...21,5 mA
pressure simulation	Setting a fixed pressure value, it also considers dampingk and tabular function unlike the current simulation	Nominal range

## Adjustment

Type	Description
zero point correction	adjusts reading to 0 bar at same pressure on both connections
position correction	adjusts reading of mounted instrument to 0 bar at same pressure on both connections
lower adjustment	adjusts reading to applied pressure (affects zero point + span)
upper adjustment	adjusts reading to applied pressure (affects span only)
current adjustment	adjusts current output to achieve 4 resp. 20 mA at the end of the measurement chain

## Connection diagram

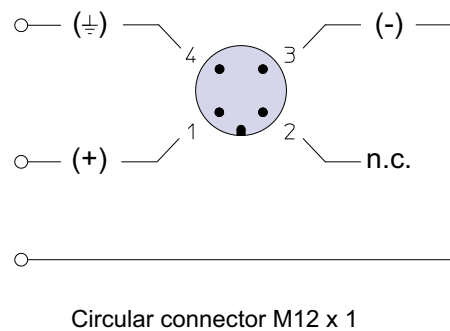
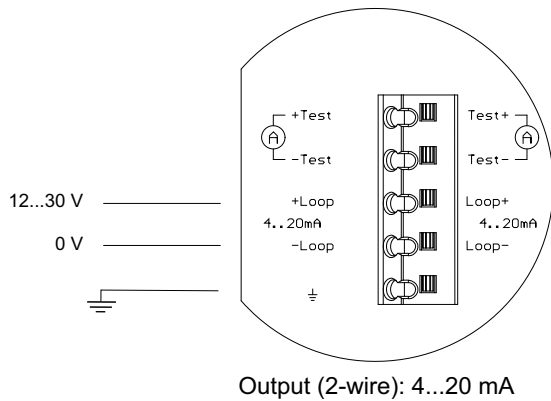

## Dimensions

### Case and process connections

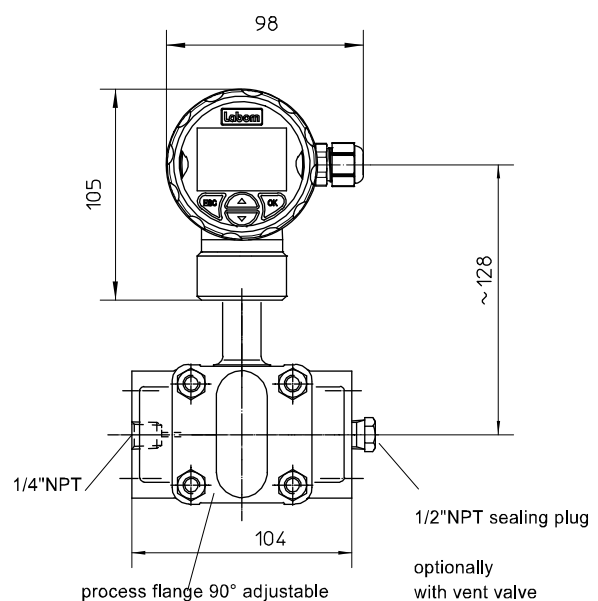
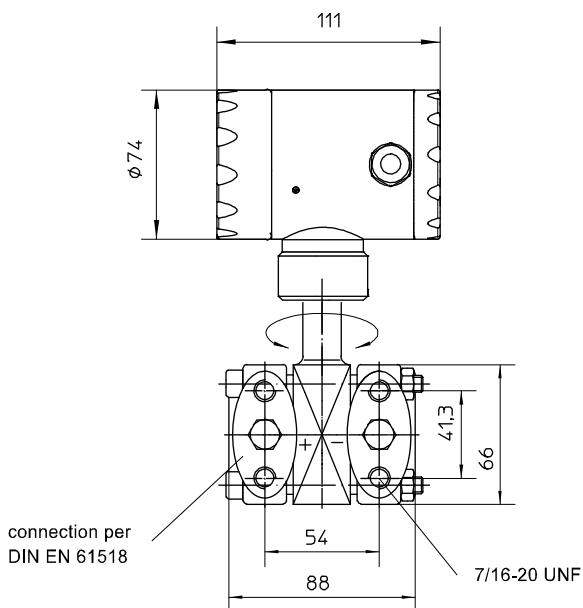

All dimensions are in mm

**Follow-up case and process connections**

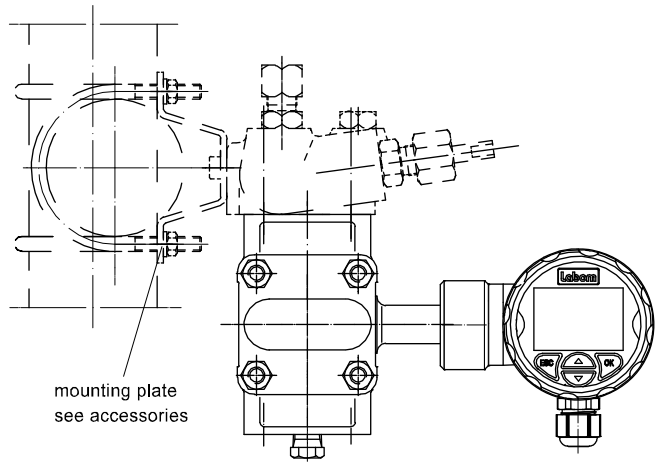
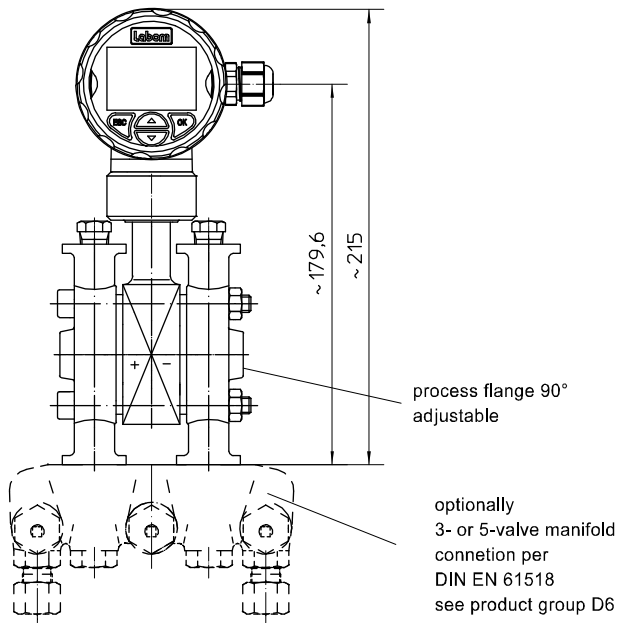
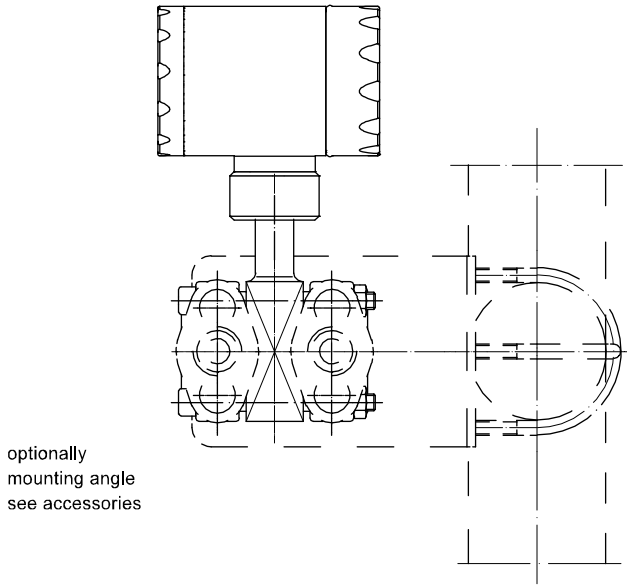
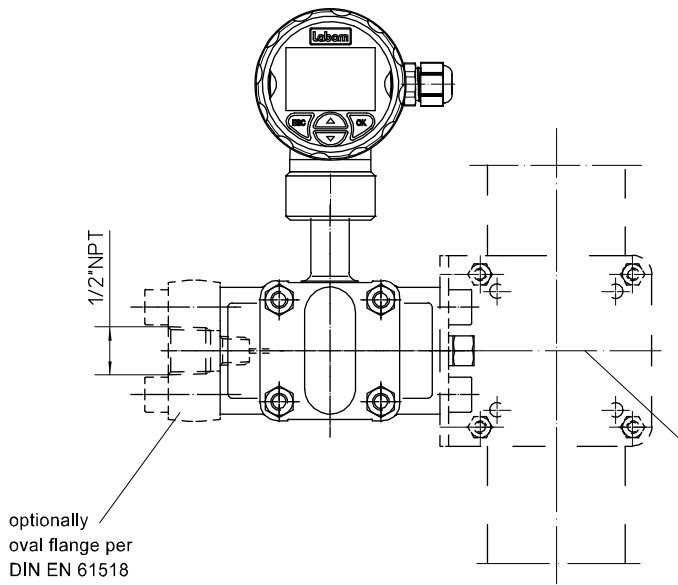

All dimensions are in mm

## Electrical connection

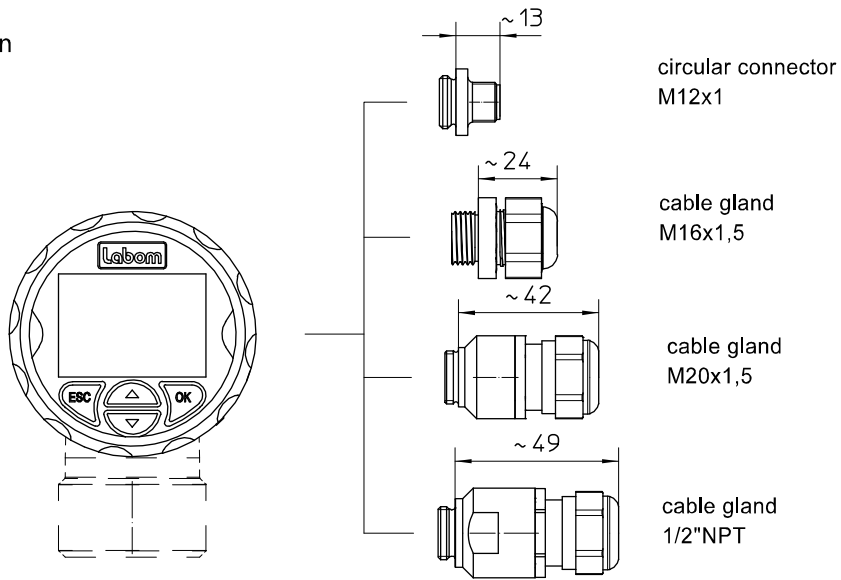

## Remote display and control unit (Type series MC1140)

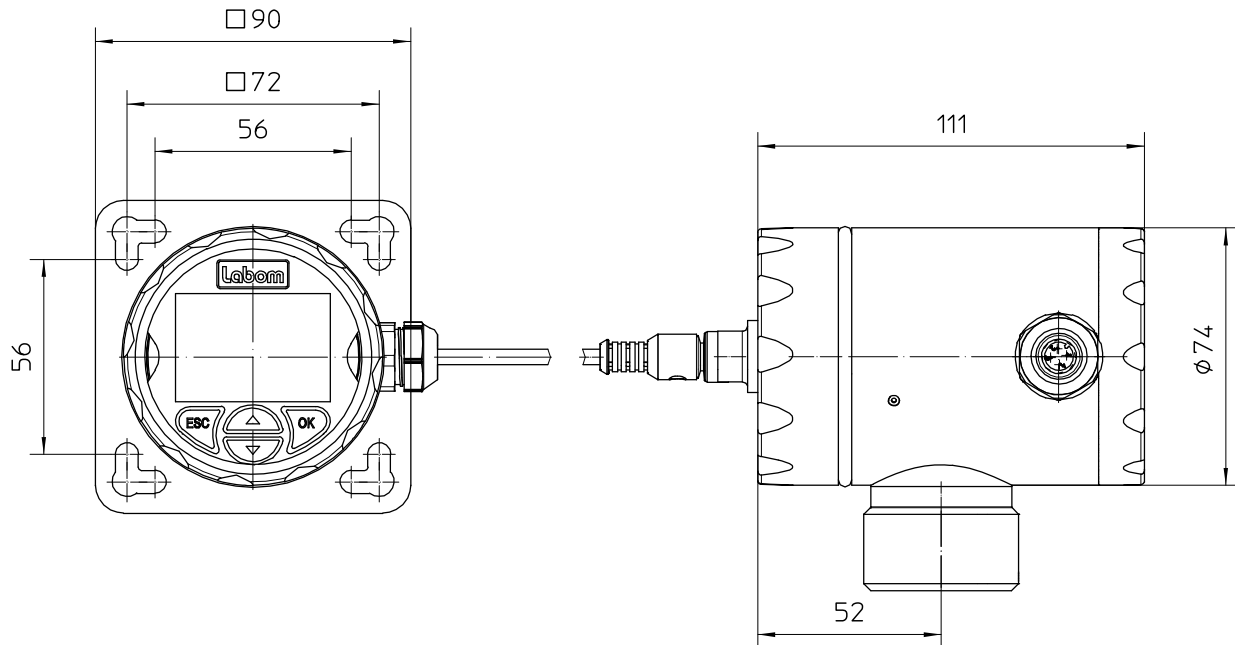

## Mounting angle for wall and pipe-mounting (Type series MM1500)

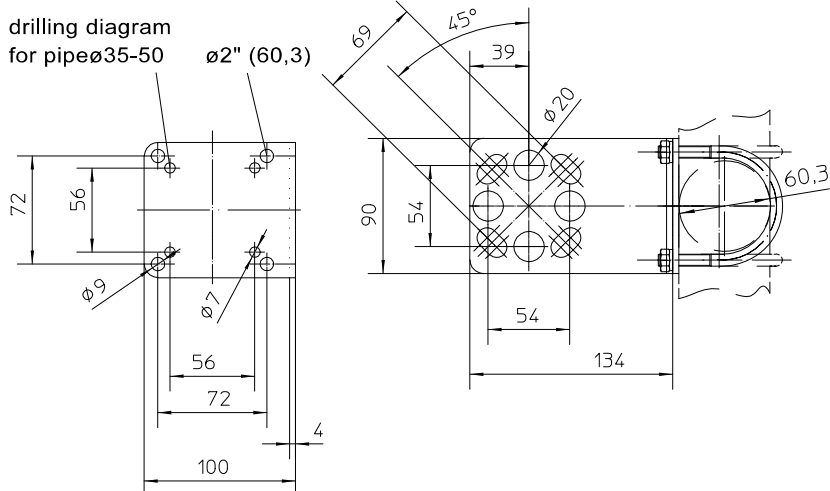

All dimensions are in mm



## Order details

### Differential pressure transmitter PASCAL Ci4 Delta P for general application, Type series CI4300

Order details PASCAL Ci4 Delta P CI4300				
CI4300	Differential pressure transmitter PASCAL Ci4 Delta P for general application			
A1078	measuring range	-0.25...0.25 bar		
A1053		-1...1 bar		
A1056		-1...4 bar		
A1059		-1...16 bar		
A1061		-1...40 bar		
F1	parameterisation	factory settings (standard)		
F2		as per customer's specification (pls. specify)		
H21	output signal	4...20 mA, with HART-protocol		
Y1.	material case	stainless steel mat.-no. 1.4301/1.4305 (304/303)		
Y2.		stainless steel mat.-no. 1.4404 (316L)		
1	material front cover	polypropylene (black), window Macrolon		
2		stainless steel (see case), window non-splintering glass		
3		stainless steel (see case), closed, without window		
			default language	available language
	display	high-resolution graphic display with backlight, intuitive 4-button operation, quick access to device data	German (standard)	English, German
M21.1			English	
M22.1			English	English, Chinese
M22.2			Chinese	
M23.1			English	English, Spanish, French
M23.2			Spanish	
M23.3			French	
M25.1			English	English, Polish, German
M25.2			Polish	
M25.3			German	
M26.1			English	English, Turkish, German
M26.2			Turkish	
M26.3			German	
M1			without display	
T20.	electrical connection	cable gland	M16 x 1.5 polyamide, for cable Ø 4.5-10	
T22.			M16 x 1.5 stainless steel, for cable Ø 5-9.5 mm	
T15.			M20 x 1.5 polyamide, for cable Ø 7-13 mm	
T17.			M20 x 1.5 stainless steel, for cable Ø 8-13 mm	
T27.			1/2" NPT polyamide, for cable Ø 6-12 mm	
0			cable clamps	spring clamp terminals up to 1.5 mm <sup>2</sup>
5	pole terminals 2.5 mm <sup>2</sup>			
6	screw terminals 2.5 mm <sup>2</sup>			
T30	circular connector M12 x 1 (4-polig)			
K41..	process connection	process flange with connection dimension per DIN EN 61518 - process connection 1/4 – 18 NPT - mounting thread 7/16 – 20 UNF		
1		with sealing plug of stainless steel mat.-no.1.4571 (316Ti)		
3		with sealing plug of stainless steel 316L		
4		with ventilation valve of stainless steel mat.-no. 1.4404 (316L)		
1		gasket of FKM (Viton)		
G1	diaphragm material	stainless steel mat.-no. 1.4404 / 1.4435 (316L)		

Additional features (to be indicated if required)			
S62	Ex marking <sup>1</sup>	ATEX	⊕ II 1/2G, II 2G Ex ia IIC TX Ga/Gb, Gb
			⊕ II 1/2D, II 2D Ex ia IIIC Txx °C Da/Db, Db
S77		IECEX	Ex ia IIC TX Ga/Gb, Gb
			Ex ia IIIC Txx °C Da/Db, Db
T4	degree of protection	IP 69K <sup>1</sup>	
W1201	calibration certificate	per EN 10204-3.1, 5 measuring points	
W2602	functional safety per EN 61508, classification per SIL2		
W2673	certificate of measuring equipment for Russian Federation		
Accessories			
MM1500-A11	mounting angle	for wall and pipe-mounting Ø 35-50 mm of stainless steel, incl. screws 7/16-20 UNF	
MM1500-A12		for wall and pipe-mounting Ø 2" of stainless steel, incl. screws 7/16-20 UNF	
MC1060-A132	oval flange	oval flange 1/2-14 NPT per DIN EN 61518, modal A of stainless steel mat.-no. 1.4404 (316L), incl. 2 screws 7/16-20 UNF, material stainless steel, incl. gasket PTFE	
MC1060-A133		oval flange 1/2-14 NPT per DIN EN 61518, modal A of stainless steel mat.-no. 1.4404 (316L), incl. 2 screws 7/16-20 UNF, material stainless steel, incl. gasket FKM Viton	
MC1140	PASCAL Ci4 remote display and control unit including device holder		
	material stainless steel, incl. front ring with seal and blind cap with circular connector M12x1		
A1.	connection cable	length: 10 m, material: PUR, with circular connector M12 x1 (further lengths upon request)	
1	internal cable clamps	spring clamp terminals up to 1.5 mm <sup>2</sup>	
2		pole terminals 2.5 mm <sup>2</sup>	
3		screw terminals 2.5 mm <sup>2</sup>	
T1	degree of protection	IP 65 / IP 67 (standard)	
MZ8120-A11	mounting set for device holder	2 mounting brackets for pipe and frame mounting Ø 30-50 mm, incl. nuts and washers	
MZ8120-A12		2 mounting brackets for pipe and frame mounting Ø 40-64 mm, incl. nuts and washers	
MC1020	HART-Modem	RS 232 -interface	
MC1040		USB-interface	
MC1041		USB-interface, Ex	

Order code (example): CI4300 – A1056 – F1 – H21 – Y12 – T200 – K4111 – G1 - ...

<sup>1</sup> Requires front cover of stainless steel